

PATENT ABSTRACTS OF JAPAN

(11)Publication number : **2001-204850**

(43)Date of publication of application : **31.07.2001**

(51)Int.Cl. A63B 23/04
A63B 23/12
// A61H 1/02

(21)Application number : **2000-019577** (71)Applicant : **DAIHEN CORP**

(22)Date of filing : **28.01.2000** (72)Inventor : **URATANI TAKAFUMI**
YAMAGUCHI KOSAKU
NAKATANI FUMIHIKO
SADO DAISUKE

(54) TRAINING DEVICE

(57)Abstract:

PROBLEM TO BE SOLVED: To provide a training device having the function of changing the operating force of a user corresponding to a desired pattern, namely, ideal function for muscular power training.

SOLUTION: The training device comprises an operating arm 1 having a receiving part 2 for receiving the operating force of a user, a servo motor 7 for generating a reaction load in the receiving part 2 of the operating arm 1, and a load controller 9 for inputting a rotational position P1 from an encoder 4 and an operating torque T_{hand} from a torque meter 6 and then controlling the drive of the servo motor 7 to make a change in operating force ranging from the position of starting attitude to the position of ending attitude corresponding to operating force-positional change property preset in accordance with a load table.

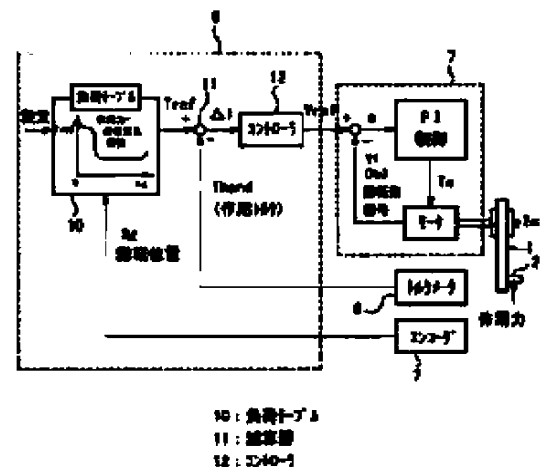

* NOTICES *

JPO and INPIT are not responsible for any damages caused by the use of this translation.

- 1.This document has been translated by computer. So the translation may not reflect the original precisely.
- 2.**** shows the word which can not be translated.
- 3.In the drawings, any words are not translated.

CLAIMS

[Claim(s)]

[Claim 1]A training apparatus comprising:

A movable body which has a force receiving portion which receives applied force from a user.

When the above-mentioned user moves the above-mentioned movable body from the initial shock posture to an ending posture, An action force detection means which detects applied force from the above-mentioned user in a training apparatus which trains the above-mentioned user's muscular power, A position detecting means which detects an attitude position of the above-mentioned movable body, a load generating means which makes the above-mentioned force receiving portion generate reaction force load of a direction which is mechanically combined with the above-mentioned movable body, and counters the above-mentioned applied force, And a load control means which controls the above-mentioned reaction force load so that change of the above-mentioned applied force which results in a position of an ending posture serves as the predetermined applied force-position change characteristic set up beforehand from a position of the above-mentioned initial shock posture.

[Claim 2]Action arms by which the other end was combined with the 1st axis of rotation in preparation for one end in a force receiving portion which receives applied force from a user, The 2nd axis of rotation connected with the 1st axis of rotation of the above via a torque meter which detects applied force from the above-mentioned user, A servo motor made to generate reaction force load of a direction which the rotation driving shaft is connected with the 2nd axis of rotation

of the above, and counters the above-mentioned applied force in the above-mentioned force receiving portion, A position detecting means which detects a rotary place of the 1st axis of rotation of the above, And so that change of the above-mentioned applied force from a position of the above-mentioned initial shock posture to [inputs an output of the above-mentioned torque meter and an output of the above-mentioned position detecting means, and] a position of an ending posture may serve as the predetermined applied force-position change characteristic set up beforehand. A training apparatus provided with a load control means which carries out drive controlling of the above-mentioned servo motor.

[Claim 3]Action arms by which the other end was combined with the axis of rotation in preparation for one end in a force receiving portion which receives applied force from a user, A servo motor made to generate reaction force load of a direction which the rotation driving shaft is connected with the above-mentioned axis of rotation, and counters the above-mentioned applied force in the above-mentioned force receiving portion, An action force detection means which detects the above-mentioned applied force from torque and revolving speed of the above-mentioned servo motor by an operation, A position detecting means which detects a rotary place of the above-mentioned axis of rotation from revolving speed of the above-mentioned servo motor by an operation, And so that change of the above-mentioned applied force from a position of the above-mentioned initial shock posture to [inputs an output of the above-mentioned action force detection means and an output of the above-mentioned position detecting means, and] a position of an ending posture may serve as the predetermined applied force-position change characteristic set up beforehand. A training apparatus provided with a load control means which carries out drive controlling of the above-mentioned servo motor.

[Claim 4]A load table which memorized relation between applied force instructions to which a load control means was set corresponding to the predetermined applied force-position change characteristic, and a rotary place of the axis of rotation, And the training apparatus according to claim 2 or 3 provided with a speed command creation circuit which creates a speed command of a servo motor so that applied force instructions equivalent to a detection value of a rotary place may be read in the above-mentioned load table and a detection value of applied force may be in agreement with the above-mentioned applied force instructions.

[Claim 5]The training apparatus according to claim 4 when a speed command creation circuit is [a detection value of applied force] below applied force

instructions, wherein it sets a speed command of a servo motor as zero.

[Claim 6]When it has a movable body which has a force receiving portion which receives applied force from a user, and the above-mentioned user moves the above-mentioned movable body from the initial shock posture to an ending posture, A position detecting means which detects an attitude position of the above-mentioned movable body in a training apparatus which trains the above-mentioned user's muscular power, A load generating means which makes the above-mentioned force receiving portion generate reaction force load of a direction which is mechanically combined with the above-mentioned movable body, and counters the above-mentioned applied force, And a training apparatus provided with a load control means which controls the above-mentioned reaction force load so that change of the above-mentioned applied force which results in a position of an ending posture serves as the predetermined applied force-position change characteristic set up beforehand from a position of the above-mentioned initial shock posture.

[Claim 7]Action arms by which the other end was combined with the axis of rotation in preparation for one end in a force receiving portion which receives applied force from a user, A motor made to generate reaction force load of a direction which the rotation driving shaft is connected with the above-mentioned axis of rotation, and counters the above-mentioned applied force in the above-mentioned force receiving portion, A position detecting means which detects a rotary place of the above-mentioned axis of rotation, a speed detection means which detects revolving speed of the above-mentioned axis of rotation, A load table which memorized relation between applied force instructions set up corresponding to the predetermined applied force-position change characteristic, and a rotary place of the axis of rotation, A speed command = so that a deviation with a speed detection value from a speed command generation circuit which outputs zero, and a zero speed command and the above-mentioned speed detection means from this speed command generation circuit may be inputted and this deviation may serve as zero, A torque command creation circuit which creates a torque command of the above-mentioned motor by control which has a proportional element and an integral element at least, And the training apparatus according to claim 6 provided with a limiting circuit which reads applied force instructions equivalent to a rotary place detection value from the above-mentioned position detecting means in the above-mentioned load table, and restricts an output of the above-mentioned torque command creation circuit so

that the read applied force instructions concerned may serve as the maximum.
[Claim 8]When a speed detection value changes in the direction which tends toward a position of an initial shock posture from a position of an ending posture and the polarity of a deviation input reverses proportional gain of a torque command creation circuit, The training apparatus according to claim 7 characterized by generating a torque command which increases rapidly by negative polarity, and making it make an output of the above-mentioned torque command creation circuit decrease rapidly with the output of this proportional gain.

[Translation done.]

* NOTICES *

JPO and INPIT are not responsible for any damages caused by the use of this translation.

- 1.This document has been translated by computer. So the translation may not reflect the original precisely.
- 2.**** shows the word which can not be translated.
- 3.In the drawings, any words are not translated.

DETAILED DESCRIPTION

[Detailed Description of the Invention]

[0001]

[Field of the Invention]This invention relates to the training apparatus offered in order to train a user's muscular power original functional recovery (rehabilitation) of the body, and for the purpose of the further muscular power rise.

[0002]

[Description of the Prior Art]Physical-workouts institutions, such as a training gym for promoting physical strength towards these, came to be established in every place with the spread of various sports in recent years. The rehabilitation facilities which aim at functional recovery of the lowered physical strength are also increasing. However, what is called a training machine installed in these institutions has many the pulley machine from the former, an external force operation machine, rubber tube machines, spring elastic machines, and oil pressure machines, and is not necessarily satisfactory as a training function.

[0003]Namely, these many are what is called what is called an ending load training machine, If load when starting extension operation from the curve condition of the body (initial shock state) will be called initial shock load and load when the last expanded state is reached (ending state) will be called ending load, In the various machines mentioned above, along with an advance of operation, load becomes large small [initial shock load], and the last ending load serves as the maximum (ending load training). However, according to the newest muscle training theory (for example, refer to Kodansha issue Koyama [Yasushi] work "new training revolution" in September, 1994), in this ending load training. It is indicated that there is a possibility of being in the state of making hardening of a

joint promoted and making a muscular elastic function losing conversely, and narrowing the excursion of a joint.

[0004]According to the theory, beginning movement load training attracts attention to such ending load training. This has the large initial shock load in an initial shock state, load becomes small along with an advance of operation, and ending load is training used as the minimum, and in this beginning movement load training. The basis part for training induces power and speed in first operation, transfer of the power to an end piece comes to be performed smoothly, and it is supposed that the capability of the body improves.

[0005]For example, JP,H9-24117,A is indicating the training apparatus which realizes this beginning movement load training. The arm concerned is made for this equipment to rise gradually because a user pulls the arm which forms a weight in the other end of an arm rotatable as a fulcrum, and is in a horizontal position mostly in the state of initial shock about one end via a rope. In this case, the load concerning a rope decreases gradually as the weight of a weight works 100%, and serves as the maximum and rotation of an arm progresses, when there is an arm of first arrival time horizontally, and it serves as what is called an initial shock load pattern.

[0006]By the way, a user's physical strength or bodily nature which train are not uniform, and the body region which should carry out functional recovery by training, and the body region which should be carried out muscular power strengthening are also various. Therefore, it is requested that the change pattern of load which results in an ending posture may also be changed from the size and initial shock posture of required load by classification for these trainings as a training apparatus.

[0007]however, the equipment of this supra gazette used the gravity of a weight, and rotation of the arm -- pure -- a machine, in order to adjust the size of load, since it is a thing of structural composition, A weight and an arm must be exchanged, it is necessary to change the weight and length, and adjustment complicated [the work of the exchange] and continuous cannot but become difficult. The fault of being limited to what is called the cosine function characteristic also has a change pattern of load on the principle, and it must be said that it is inferior to practicality as a training apparatus.

[0008]On the other hand, for example, the resistance-load equipment for movement training which can be adjusted freely is indicated by JP,S54-138736,A in the size of load. This adjusts the torque as load by adopting an electromagnetic

coupling as the generating means of load, making this electromagnetic coupling act as a brake, and changing further the exciting current supplied to this electromagnetic brake. for example, load can be changed in proportion to change of the power applied to the rod which a user moves, and load can be changed in inverse proportion to change of the applied power -- purport explanation is given. [0009]By the way, when the newest muscle training theory that the inventor etc. mentioned above was analyzed in detail, if the load was only said that it may make it change freely as a training apparatus, the insufficient thing became clear. That is, even if it sets up a load pattern which becomes low highly for the purpose of beginning movement load training at first arrival time at the time of ending, the applied force which is the power which the user who trains actually uses is uncontrollable.

[0010]This cause is as follows. That namely, | applied force |=| load | will be materialized if the case where a user grasps the end of the lever provided in equipment, and pushes this in from the initial shock position to the ending position now is assumed, It is only a time of a lever balancing to a state of rest, and must have been materialized in the process which the lever moves toward the ending position from the initial shock position according to the user's applied force. Specifically, applied force will be sharply changed depending on how to apply the size of a user's power, and power etc.

[0011]On the other hand, ideal muscle training is making a user do experience which uses the applied force of the request concerned along with the applied force pattern which becomes settled according to a user's physical strength, the body characteristic, its training subject part, etc. Therefore, even if it can control the load by the equipment of the prior art reference (JP,S54-138736,A) mentioned above, it will be impossible to make it a user's applied force change along with a desired pattern. In this point, the previously quoted prior art reference (JP,H9-24117,A) can also completely be referred to as the same.

[0012]This invention realizes the training apparatus which can be changed in accordance with the pattern of a request of the applied force which a user uses and which was provided with the function near an ideal as muscle training so to speak.

[0013]

[Means for solving problem]When the training apparatus concerning this invention is provided with the movable body which has a force receiving portion which receives the applied force from a user, and the above-mentioned user moves the

above-mentioned movable body from that initial shock posture to an ending posture, The action force detection means which detects the applied force from the above-mentioned user in the training apparatus which trains the above-mentioned user's muscular power, The position detecting means which detects the attitude position of the above-mentioned movable body, the load generating means which makes the above-mentioned force receiving portion generate the reaction force load of the direction which is mechanically combined with the above-mentioned movable body, and counters the above-mentioned applied force, And it has a load control means which controls the above-mentioned reaction force load so that change of the above-mentioned applied force which results in the position of an ending posture serves as the predetermined applied force-position change characteristic set up beforehand from the position of the above-mentioned initial shock posture.

[0014]The action arms by which the other end was combined with the 1st axis of rotation in preparation for one end in the force receiving portion with which the training apparatus concerning this invention receives the applied force from a user, The 2nd axis of rotation connected with the 1st axis of rotation of the above via the torque meter which detects the applied force from the above-mentioned user, The servo motor made to generate the reaction force load of the direction which the rotation driving shaft is connected with the 2nd axis of rotation of the above, and counters the above-mentioned applied force in the above-mentioned force receiving portion, The position detecting means which detects the rotary place of the 1st axis of rotation of the above, And it has a load control means which carries out drive controlling of the above-mentioned servo motor so that change of the above-mentioned applied force from the position of the above-mentioned initial shock posture to [inputs the output of the above-mentioned torque meter and the output of the above-mentioned position detecting means, and] the position of an ending posture may serve as the predetermined applied force-position change characteristic set up beforehand.

[0015]The action arms by which the other end was combined with the axis of rotation in preparation for one end in the force receiving portion with which the training apparatus concerning this invention receives the applied force from a user, The servo motor made to generate the reaction force load of the direction which the rotation driving shaft is connected with the above-mentioned axis of rotation, and counters the above-mentioned applied force in the above-mentioned force receiving portion, The action force detection means which detects the above-

mentioned applied force from the torque and revolving speed of the above-mentioned servo motor by an operation, The position detecting means which detects the rotary place of the above-mentioned axis of rotation from the revolving speed of the above-mentioned servo motor by an operation, And it has a load control means which carries out drive controlling of the above-mentioned servo motor so that change of the above-mentioned applied force from the position of the above-mentioned initial shock posture to [inputs the output of the above-mentioned action force detection means and the output of the above-mentioned position detecting means, and] the position of an ending posture may serve as the predetermined applied force-position change characteristic set up beforehand.

[0016]The load control means of the training apparatus concerning this invention, The load table which memorized the relation between the applied force instructions set up corresponding to the predetermined applied force-position change characteristic, and the rotary place of the axis of rotation, And the applied force instructions equivalent to the detection value of a rotary place are read in the above-mentioned load table, and it has a speed command creation circuit which creates the speed command of a servo motor so that the detection value of applied force may be in agreement with the above-mentioned applied force instructions.

[0017]The speed command creation circuit of the training apparatus concerning this invention sets the speed command of a servo motor as zero, when the detection value of applied force is below applied force instructions.

[0018]When the training apparatus concerning this invention is provided with the movable body which has a force receiving portion which receives the applied force from a user, and the above-mentioned user moves the above-mentioned movable body from that initial shock posture to an ending posture, The position detecting means which detects the attitude position of the above-mentioned movable body in the training apparatus which trains the above-mentioned user's muscular power, The load generating means which makes the above-mentioned force receiving portion generate the reaction force load of the direction which is mechanically combined with the above-mentioned movable body, and counters the above-mentioned applied force, And it has a load control means which controls the above-mentioned reaction force load so that change of the above-mentioned applied force which results in the position of an ending posture serves as the predetermined applied force-position change characteristic set up

beforehand from the position of the above-mentioned initial shock posture.

[0019]The action arms by which the other end was combined with the axis of rotation in preparation for one end in the force receiving portion with which the training apparatus concerning this invention receives the applied force from a user, The motor made to generate the reaction force load of the direction which the rotation driving shaft is connected with the above-mentioned axis of rotation, and counters the above-mentioned applied force in the above-mentioned force receiving portion, The position detecting means which detects the rotary place of the above-mentioned axis of rotation, the speed detection means which detects the revolving speed of the above-mentioned axis of rotation, The load table which memorized the relation between the applied force instructions set up corresponding to the predetermined applied force-position change characteristic, and the rotary place of the axis of rotation, Speed command = so that a deviation with the speed detection value from the speed command generation circuit which outputs zero, and the zero speed command and the above-mentioned speed detection means from this speed command generation circuit may be inputted and this deviation may serve as zero, The torque command creation circuit which creates the torque command of the above-mentioned motor by control which has a proportional element and an integral element at least, And the applied force instructions equivalent to the rotary place detection value from the above-mentioned position detecting means are read in the above-mentioned load table, and it has a limiting circuit which restricts the output of the above-mentioned torque command creation circuit so that the read applied force instructions concerned may serve as the maximum.

[0020]Proportional gain of a torque command creation circuit in a training apparatus concerning this invention, When a speed detection value changes in the direction which tends toward a position of an initial shock posture from a position of an ending posture and the polarity of a deviation input is reversed, a torque command which increases rapidly by negative polarity is generated, and it is made to make an output of the above-mentioned torque command creation circuit decrease rapidly with the output of this proportional gain.

[0021]

[Mode for carrying out the invention]embodiment 1. -- before starting explanation of a concrete example of composition first, the state where it is actually training using a training apparatus which becomes an application concerned is shown in drawing 1 in image. Although training is performed mainly for the limbs of a

human body, each drawing 1 targets membrum inferius. By a movable part, with the figure (a), a user sits on a portion of a seat and a portion enclosed with a dotted line performs operation which a receive part of an action-arms end later mentioned by instep is made from lower end position of an initial shock state to a horizontal position of an ending state. The figure (b) trains in a form which steps on a receive part of action arms by a planta pedis. The figure (c) pushes down regions of back of a seat, presupposes that it is level, and trains by a user's becoming proneness and moving a receive part of action arms from a horizontal position to an upper bed position in a portion of the heel of a leg on this horizontal table.

[0022]Drawing 2 is a figure showing the example of representation of the target applied force-position change characteristic. To explain in full detail in the latter part, the actuator of action arms is controlled so that the power and applied force which a user actually feels follow the curve top of the applied force-position change characteristic of a figure in footsteps. Each of the 1 of drawing 2 and its 2 is based on the initial shock load theory mentioned already, and the 1 is a common training pattern, and the 2, For example, it is applied to leg muscle training in case a marathon runner etc. begin to kick a ground surface etc., where an actuator is stopped first, it goes into an initial shock posture, and operation is started when the maximum to which the detection value of applied force was set is exceeded.

[0023]Next, a concrete embodiment is described. Drawing 3 is a block diagram of the training apparatus in this embodiment of the invention 1 showing especially a working part. In the figure, 1 is the action arms as a movable body, and the end serves as the force receiving portion 2 which is bent right-angled and receives the applied force from a user. And the other end of the action arms 1 is combined with the 1st axis of rotation 3. The encoder as a position detecting means with which 4 detects the rotary place Pl of the 1st axis of rotation 3, The 2nd axis of rotation in which 5 was connected with the 1st axis of rotation 3 via the torque meter 6 as an action force detection means, and 7 are the servo motors as a load generating means with which the rotation driving shaft was connected with the 2nd axis of rotation 5 via the deceleration mechanism 8. The torque meter 6 outputs the operation torque T_{hand} equivalent to applied force.

[0024]A servo motor is a motor of the system which creates a torque command and is rotated based on this torque command so that the deviation input of the speed command V_{ref} inputted and the speed detection value from the encoder to

build in may serve as zero, For example, although a DC servo motor, a synchronized type AC servo motor, a induction type AC servo motor, etc. can apply, as long as the above-mentioned drive controlling composition is provided, what is called a hydraulic servomotor etc. that use fluid (oil etc.) energy for a driving source, for example are applicable.

[0025]9 is a load control device explained in full detail in the latter part, and inputs the operation torque T_{hand} from the rotary place PI and the torque meter 6 from the encoder 4, The speed command V_{ref} is outputted to the servo motor 7 so that the applied force from a user might be set up beforehand, for example, it may follow in footsteps of the predetermined applied force-position change characteristic that it explained by drawing 2.

[0026]Drawing 4 is a block diagram of the training apparatus in this embodiment of the invention 1 showing especially a control mechanism, and the mark of each part is made to correspond to each part of drawing 3. In drawing 4, it is the load table which memorized the applied force-position change characteristic that it explained by drawing 2, and 10 comprises a ROM etc. which memorized the relation of operation torque command T_{ref} and the rotary place PI for specifying the characteristic in the form of the table. What is necessary is for the load table 10 to set up beforehand several different characteristics according to a user or a training program by the suitable input means, and to choose a required thing and just to apply it out of the table of these plurality, at every use.

[0027]Although a graphic display is omitted, a user and an observer may be made to establish an input means into which a setting detail of this load table 10 can be changed suitably during training operation. Although a graphic display is similarly omitted, When a means to detect body data (for example, a pulse, blood pressure, etc.) of a user under training operation is formed and this body data arrives at a critical region set up beforehand, A preset value of an operation torque command of the load table 10 is lowered automatically, and it may enable it to change or suspend training operation safely.

[0028]A subtractor which calculates torque deviation ΔT with the operation torque T_{hand} detected with operation torque command T_{ref} equivalent to the rotary place PI from the encoder 4 where 11 was read in the load table 10, and the torque meter 6, A controller which creates the speed command V_{ref} which 12 gives to the servo motor 7 so that inputted torque deviation ΔT may become zero, and 7 are servo motors, Although mentioned already, it has a PI control machine which gives torque command T_c to a motor so that the velocity error e

with the rotation speed signal V_f (Nm) which is the revolving speed of a motor which is a driving source, and the inputted speed command V_{ref} and a detected motor may serve as zero so that it may be shown within the dotted-line limit of a figure.

[0029]Next, operation of this equipment at the time of training execution is explained also with reference to the flow chart shown in drawing 5. If a user applies power to the force receiving portion 2 of the action arms 1 (i.e., if set to operation torque $T_{hand} > 0$), it will start (Step S0). The following operations are performed a predetermined control cycle. First, [whether the rotary place PI detected from the encoder 4 is between the initial shock position ($PI=0$) of training, and an ending position ($PI=PI_{max}$), and] That is, it judges whether $0 \leq PI \leq PI_{max}$ is materialized, if it is No, operation will be ended, and if it is Yes, it will go into the following original control actions (Step S1). Then, operation torque command T_{ref} equivalent to the rotary place PI at that time is read in the load table 10 at Step S2.

[0030]Next, it is judged whether it is materialized that it is beyond the operation torque T_{hand} that operation torque command T_{ref} read in the load table 10 detected from the torque meter 6, i.e., $T_{hand} \leq T_{ref}$, (Step S3). When Yes T_{hand} , i.e., the operation torque from a user, is not over operation torque command T_{ref} at Step S3, speed command $V_{ref}=0$ is outputted to the servo motor 7 from the controller 12 (step S4). Therefore, in order that the servo motor 7 may attain that rotation speed signal $V_f=V_{ref}=0$ in this case, the motor torque T_m which is the reaction force load which counters the operation torque T_{hand} is generated (Step S5). When this moderating ratio is set to R_m , the motor torque T_m is made generated so that $T_{hand}=R_m \cdot T_m$ may be materialized since the deceleration mechanism 8 is formed between the 2nd axis of rotation 5 in which the action arms 1 were combined, and the rotation driving shaft of the servo motor 7 as drawing 3 explained.

[0031]If the motor torque T_m is generated at Step S5, the control action of the unit period concerned will be finished, it will return to Step S1, and operation of the following cycle will be repeated. For example, supposing the applied force-position change characteristic set up with the load table 10 is a pattern shown in the 2 of previous drawing 2, The operation which passes along step S4 mentioned above will be repeated, and the action arms 1 will hold a halt condition as a result until the operation torque T_{hand} in $PI=0$, i.e., an initial shock position, exceeds the value (T_{refmax}) in P point of the pattern of drawing 2 (the 2). If it puts in another

way, the pattern of the rising portion of the applied force-position change characteristic set up by drawing 2 (the 2) will be reproduced faithfully.

[0032]If the operation torque T_{hand} from a user exceeds operation torque command T_{ref} from the load table 10 (it is No at Step S3), the controller 12 so that the torque deviation $\Delta T = T_{ref} - T_{hand}$ may serve as zero, For example, the speed command V_{ref} outputted to the servo motor 7 based on the function $Func(T_{ref} - T_{hand})$ shown by the following (1) formulas is created (Step S6).

[0033]

[Mathematical formula 1]

$$\mathbf{V_{ref} = Func(T_{ref} - T_{hand})}$$

$$= K \left\{ (T_{ref} - T_{hand}) + \frac{1}{T_i} \int (T_{ref} - T_{hand}) dt \right\} \quad \dots(1)$$

[0034]The controller 12 comprises a PI control system and K of (1) type and T_i are the parameters of PI, respectively.

[0035]When the servo motor 7 generates the motor torque T_m based on the speed command V_{ref} created at Step S6, the action arms 1 will begin rotation according to the difference of the operation torque T_{hand} and the motor torque T_m (correctly $R_m - T_m$), namely, will begin to move to direction of an ending posture. It follows in footsteps of the applied force-position change characteristic that the rise of the operation torque T_{hand} was controlled by this motion, and that value was set up. After the action arms 1 result [from the initial shock posture] in an ending posture and one cycle of training finishes, judgment of Step S1 serves as No, and ends a series of control actions.

[0036]As mentioned above, the training apparatus by this embodiment of the invention 1, Since the reaction force load by the servo motor which counters the above-mentioned applied force is controlled so that a user's applied force turns into applied force which met the desired applied force-position change characteristic, a user can be provided with training experience as a request. And since the applied force-position change characteristic can be set up very simple, of course, what is called beginning movement load training in consideration of the newest muscle training theory can set up the applied force-position change characteristic of arbitrary patterns according to the item for training, a user's physical strength, etc.

[0037]The controller 12 which makes torque deviation $\Delta T = T_{ref} - T_{hand}$ an input and creates the speed command V_{ref} of the servo motor 7, As Steps S3-S6

of drawing 5 explained, it is if $T_{hand} \leq T_{ref}$ then $V_{ref} = 0$ else $V_{ref} = \text{Func}(T_{ref} - T_{hand})$.

Since it is alike and was made to operate by the shown logic, while the control made to follow in footsteps of the applied force-position change characteristic is made smoothly, the operation torque T_{hand} , Setting-out applied force as made put an initial shock load characteristic into practice, for example, shown in the 2 of drawing 2 can make it follow in footsteps certainly also to the characteristic which begins from a high value.

[0038] Since the speed command V_{ref} from the controller 12 serves as zero promptly when a user decreases the applied force rapidly to this side which results in an ending posture for a certain Reason or uses original direction of training, and the power for reverse, The danger that a user pushes shockingly and it is contrary to him by the reaction force load by the servo motor 7 is prevented.

[0039] Although the torque meter 6 and the encoder 4 which were formed for exclusive use, respectively had detected the creation torque T_{hand} and the rotary place PI required for control in Embodiment 1 of the embodiment 2. point, As this Embodiment 2 searches for these information by an operation based on the signal from the servo motor 7, it makes the detector of these exclusive use unnecessary, and it is attaining the cost cut of equipment, and the miniaturization.

[0040] Drawing 6 is a block diagram of the training apparatus in this embodiment of the invention 2 showing especially a working part. Hereafter, it explains focusing on a different point from Embodiment 1. Here, the axis of rotation 3 which combines the action arms 1 is connected with the rotation driving shaft of the servo motor 7 via the deceleration mechanism 8 as it is. And the torque signal T_m and the rotation speed signal N_m required in order to calculate operation torque and a rotary place are sent to the load control device 9A from the servo motor 7.

[0041] Drawing 7 is a block diagram of the training apparatus in this embodiment of the invention 2 showing especially a control mechanism, and the mark of each part is made to correspond to each part of drawing 6. In drawing 7, 13 is the torque signal T_m (actually) from the servo motor 7. it computes from the armature current of a motor -- having -- in the arithmetic circuit as an action force detection means which creates operation torque operation value T_l from the rotation speed signal N_m . This operation is called for based on the following equations of motion, and a value almost equal to the operation torque T_{hand} detected by the torque meter 6 with the previous form 1 is obtained. That is,

TI**Thand is materialized. That is, (2) equations are materialized as the equation of motion.

[0042]

[Mathematical formula 2]

$$T_m - \frac{T_{hand}}{R_m} = J \cdot \dot{N}_m + f \cdot N_m \quad \dots(2)$$

[0043]Here, as for the moderating ratio of the deceleration mechanism 8, and J, motor shaft equivalent inertia and f of Rm are motor shaft equivalent frictions. (2) A formula is transformed and (3) types are obtained.

[0044]

[Mathematical formula 3]

$$T_{hand} = (T_m - J \cdot \dot{N}_m - f \cdot N_m) \cdot R_m \quad \dots(3)$$

[0045]Therefore, if an arithmetic control cycle is set to tau, operation torque operation value TI (k) in the k-th cycle can be calculated by (4) types from the torque signal value Tm (k-1) and the rotation speed signal value Nm (k-1) in a ** (k-1) cycle.

[0046]

[Mathematical formula 4]

$$T_l(k) = \text{Func}(T_m(k-1), N_m(k-1)) \\ = \left(T_m(k-1) - J \cdot \frac{\partial N_m(k-1)}{\partial \tau} - f \cdot N_m(k-1) \right) \cdot R_m \quad \dots(4)$$

[0047]It returns to drawing 7, and 14 is an arithmetic circuit as a position detecting means which creates the rotary place PI by an operation from the rotation speed signal Nm of the servo motor 7, and in the block, it can be calculated by the following (5) types so that it may illustrate.

PI=Nm -(1/Rm)-(1-/s)... (5), however s are Laplace operators.

[0048]By adopting operation value TI created as the operation torque Thand in the arithmetic circuit 13, and adopting the operation value PI created as the rotary place PI in the arithmetic circuit 14, The control action made to follow in footsteps of the applied force-position change characteristic of a request of a user's applied force becomes possible completely like previous Embodiment 1.

[0049]As mentioned above, in this Embodiment 2, the torque signal Tm and the

rotation speed signal N_m (V_f) which certainly exist in a servo motor are utilized effectively, Since it asked for the operation torque T_{hand} required for control, and the rotary place PI by an operation from both the above-mentioned signals, without adopting a special detection means (the torque meter 6 and the encoder 4), the miniaturization of equipment and a cost cut are realized.

[0050]Although the control system set to $V_{ref}=0$ was adopted in the controller 12 of the load control device 9 in the above example of a form at the time of $T_{hand} \leq T_{ref}$, The pattern or the control system which, in addition to this, not necessarily added the above-mentioned discrimination condition depending on training conditions of the applied force-position change characteristic set up are not adopted, but it may be made to apply the usual control system which makes torque deviation $\Delta T = T_{ref} - T_{hand}$ zero.

[0051]The speed command V_{ref} is created so that the detection operation torque T_{hand} (TI) may be in agreement with operation torque command T_{ref} read in the load table 10 according to the rotary place PI in Embodiments 1 and 2 of the embodiment 3. point, Although the speed command control system which gives this speed command V_{ref} to the servo motor 7 was adopted, In this Embodiment 3, speed command $V_{ref}=0$ is given to this as a servo motor, Based on the deviation of this speed command $V_{ref}=0$ and the detection speed (rotation speed signal) V_f , the torque command control which gives torque command T_c to a motor so that the operation torque of the request according to the load table 10 may be generated is adopted.

[0052]Drawing 8 is a block diagram of the training apparatus in Embodiment 3 showing especially a control mechanism. In a figure, the speed command generation circuit where 15 outputs speed command $V_{ref}=0$, and 16 are subtractors which calculate the velocity error e with the rotation speed signal V_f of speed command $V_{ref}=0$ from the speed command generation circuit 15, and a motor (N_m). 17 is a controller of the PI control which creates torque command T_c to a motor based on the velocity error e , it has the proportional element 18 and the integral element 19, adds output-value T_p from each, and T_T with the adding machine 20, and outputs them as torque command T_c .

[0053]21 is a limiting circuit restricted so that operation torque command T_{ref} equivalent to the rotary place PI at the time of [the] reading in the load table 10 the output calculated with the integral element 19 may serve as the maximum. In the case of the original operating state of training by which the velocity error e is

negative, and the rotation speed signal V_f is positive, therefore the action arms 1 are going to the ending position from the initial shock position, He sets up the proportional gain K_p small and is trying to become $T_T \gg T_p$ so that the characteristic may be shown within the limit of the proportional element 18.

[0054]On the other hand, when the rotation speed signal V_f becomes negative and the velocity error e is just reversed by the case where a user operates the action arms 1 in the direction contrary even to it in the middle of operation of training etc., as shown in a figure, the proportional gain K_p is set up increase rapidly by negative polarity. As a result, if this velocity error e is reversed, torque command T_c to a motor will decrease rapidly. Therefore, the danger of being rapidly aggressiveness anti-[of the user] carried out by the reaction force load by a motor in this case is prevented.

[0055]Next, operation of this equipment in the case of performing original training which tends toward an ending posture is explained from an initial shock posture also with reference to the flow chart shown in drawing 9. If a user applies power to the force receiving portion 2 of the action arms 1, it will be set to operation torque $T_{hand} > 0$ and will start (Step T0). The following operations are performed a predetermined control cycle. First, it is judged whether the rotary place PI called for based on the rotation speed signal V_f of a motor (N_m) in the arithmetic circuit 14 is between the initial shock position ($PI=0$) of training, and an ending position ($PI=PI_{max}$) (Step T1). Operation will be ended if it is No.

[0056]If it is Yes at Step T1, speed command $V_{ref}=0$ will be inputted from the speed command generation circuit 15. Although 7A shown by the dotted-line frame of previous drawing 8 constitutes the servo motor controlled according to the velocity error V_{ref} , this Embodiment 3 always gives velocity-error $V_{ref}=0$ to this servo motor 7A. The velocity error e of the velocity error V_{ref} and the rotation speed signal V_f from a motor is calculated (step T3), and torque command T_c is created by PI control based on this velocity error e (step S4).

[0057]By the way, that maximum is restricted to operation torque command T_{ref} from which the output by this PI control was read in the load table 10 by the limiting circuit 21 at Step T5 corresponding to the rotary place PI . Therefore, when the output by this PI control has not reached the limiter area of the limiting circuit 21, If it puts in another way, the operation torque T_{hand} at the time of below the torque set up in the applied force-position change characteristic. Since the value of the torque command for making the velocity error e into zero is given to a motor

as T_c as it is, a motor will generate the reaction force load T_m equal to the operation torque T_{hand} , and the action arms 1 will maintain a state of rest.

[0058]If the operation torque T_{hand} exceeds the torque set up in the applied force-position change characteristic, The value of the torque command for the output by PI control arriving at the limiter area of the limiting circuit 21, namely, making the velocity error e into zero will not be outputted as it is, but the value restricted to the value lower than it will be given to a motor as T_c . For this reason, it becomes $T_{hand} > T_m$, the action arms 1 move by this difference in the direction of applied force, and it becomes a form from which a fixed quantity of power which he applied will escape if it sees from a user, and applied force is reaching the ceiling and will follow in footsteps of the applied force-position change characteristic as a result.

[0059]In this Embodiment 3, without using the detection value (or detection value based on an operation) of operation torque, it can control so that the applied force actually committed to the action arms 1 follows in footsteps of the desired applied force-position change characteristic. That is, about operation torque, it does not have a feedback control system but, so to speak, has become an open control system. Therefore, as compared with the case where it has a feedback control system of previous Embodiments 1 and 2, the stability of the control action is excellent.

[0060]Although the rotary place PI was considered as the composition for which it asks by an operation from the rotation speed signal V_f of a motor (Nm) in drawing 8 and drawing 9, it cannot be overemphasized that the direct detection value by an encoder etc. may be used. Although the controller 17 shall consist of the proportional element 18 and the integral element 19, it is good also as what added the derivative element.

[0061]Although the deceleration mechanism 8 is made to intervene in each example of a form mentioned already between the axis of rotation in which the action arms 1 were combined, and a rotation driving shaft of a motor, It is good also as composition which links a motor with the above-mentioned axis of rotation directly via this deceleration mechanism 8 depending on classification of a motor, and the invention in this application does same effect so with having mentioned above also in that case.

[0062]in each example of a form mentioned already, it moves only in the direction which a process from an initial shock posture of training to an ending posture starts and keeps away from movement of one way of the action arms 1, for

example, a user's near side,, although aimed at a system of ONE WAY so to speak, Although there are some which perform reciprocation operation depending on classification of training, this invention can be applied also like these types of training, and does an equivalent effect so. That is, after training of one way is completed with an ending posture, to reset as a start-up posture of training of an opposite direction, and what is necessary is just made to perform a control action of the opposite direction concerned by switching the polarity of a required input output end of a control circuit at this time.

[0063]In each example of a form mentioned already, therefore a user imposed applied force on the force receiving portion 2 formed in the other end of the action arms 1 by which one end was combined with the axis of rotation, made this force receiving portion 2 into a thing of structure which moves a circumference orbit toward an ending posture from an initial shock posture, but. Although a thing of a type which this force receiving portion moves in a linear track depending on classification of training is also needed for example, this invention can be applied also like these types of training, and does an equivalent effect so. That is, what is necessary is just to change the above-mentioned straight-line motion into rotational movement of the axis of rotation by combining with the axis of rotation action arms which carry out a straight-line motion via suitable gear mechanics, for example with a force receiving portion. Therefore, let "action arms combined with the axis of rotation" indicated to Claims of Description of this application be a concept included also when both are combined with composition including conversion of the move direction as shown above.

[0064]Although muscle training explained above that what is called beginning movement load training was an ideal, if it is in application of the equipment of the invention in this application, it cannot be overemphasized that the applied force-position change characteristic set up with the load table 10 can be set not only as an initial shock load pattern but as arbitrary patterns.

[0065]

[Effect of the Invention]As mentioned above, the training apparatus concerning this invention, When it has a movable body which has a force receiving portion which receives the applied force from a user, and the above-mentioned user moves the above-mentioned movable body from the initial shock posture to an ending posture, The action force detection means which detects the applied force from the above-mentioned user in the training apparatus which trains the above-mentioned user's muscular power, The position detecting means which detects the

attitude position of the above-mentioned movable body, the load generating means which makes the above-mentioned force receiving portion generate the reaction force load of the direction which is mechanically combined with the above-mentioned movable body, and counters the above-mentioned applied force, And since it had the load control means which controls the above-mentioned reaction force load so that change of the above-mentioned applied force which results in the position of an ending posture might serve as the predetermined applied force-position change characteristic set up beforehand from the position of the above-mentioned initial shock posture, The muscle training as a request which follows in footsteps of the arbitrary applied force-position change characteristics that the applied force which a user actually imposes was defined beforehand becomes possible.

[0066]The action arms by which the other end was combined with the 1st axis of rotation in preparation for one end in the force receiving portion with which the training apparatus concerning this invention receives the applied force from a user, The 2nd axis of rotation connected with the 1st axis of rotation of the above via the torque meter which detects the applied force from the above-mentioned user, The servo motor made to generate the reaction force load of the direction which the rotation driving shaft is connected with the 2nd axis of rotation of the above, and counters the above-mentioned applied force in the above-mentioned force receiving portion, The position detecting means which detects the rotary place of the 1st axis of rotation of the above, And since it had the load control means which carries out drive controlling of the above-mentioned servo motor so that change of the above-mentioned applied force from the position of the above-mentioned initial shock posture to [inputs the output of the above-mentioned torque meter and the output of the above-mentioned position detecting means, and] the position of an ending posture might serve as the predetermined applied force-position change characteristic set up beforehand, Load control with high accuracy which real-detected a user's applied force and the rotary place of action arms is realized.

[0067]The action arms by which the other end was combined with the axis of rotation in preparation for one end in the force receiving portion with which the training apparatus concerning this invention receives the applied force from a user, The servo motor made to generate the reaction force load of the direction which the rotation driving shaft is connected with the above-mentioned axis of rotation, and counters the above-mentioned applied force in the above-mentioned

force receiving portion, The action force detection means which detects the above-mentioned applied force from the torque and revolving speed of the above-mentioned servo motor by an operation, The position detecting means which detects the rotary place of the above-mentioned axis of rotation from the revolving speed of the above-mentioned servo motor by an operation, And since it had the load control means which carries out drive controlling of the above-mentioned servo motor so that change of the above-mentioned applied force from the position of the above-mentioned initial shock posture to [inputs the output of the above-mentioned action force detection means and the output of the above-mentioned position detecting means, and] the position of an ending posture might serve as the predetermined applied force-position change characteristic set up beforehand, A means to actually detect applied force and the rotary place of action arms becomes unnecessary, and small size of equipment and cheap-ization are realized.

[0068]The load control means of the training apparatus concerning this invention, The load table which memorized the relation between the applied force instructions set up corresponding to the predetermined applied force-position change characteristic, and the rotary place of the axis of rotation, And since it had the speed command creation circuit which creates the speed command of a servo motor so that the applied force instructions equivalent to the detection value of a rotary place might be read in the above-mentioned load table and the detection value of applied force might be in agreement with the above-mentioned applied force instructions, The desired characteristic can be set up arbitrarily and simple as the applied force-position change characteristic.

[0069]The speed command creation circuit of the training apparatus concerning this invention, Since the speed command of the servo motor was set as zero when the detection value of applied force was below applied force instructions, The action arms operate smoothly toward an ending posture from an initial shock posture, and even if it operates that a user loosens the applied force suddenly in the process etc., a risk of the reaction force load by a servo motor working to a user will be prevented.

[0070]When the training apparatus concerning this invention is provided with the movable body which has a force receiving portion which receives the applied force from a user, and the above-mentioned user moves the above-mentioned movable body from that initial shock posture to an ending posture, The position detecting means which detects the attitude position of the above-mentioned movable body

in the training apparatus which trains the above-mentioned user's muscular power, The load generating means which makes the above-mentioned force receiving portion generate the reaction force load of the direction which is mechanically combined with the above-mentioned movable body, and counters the above-mentioned applied force, And since it had the load control means which controls the above-mentioned reaction force load so that change of the above-mentioned applied force which results in the position of an ending posture might serve as the predetermined applied force-position change characteristic set up beforehand from the position of the above-mentioned initial shock posture, The muscle training as a request to which the applied force which a user actually imposes follows in footsteps of the arbitrary applied force-position change characteristics defined beforehand becomes possible, without having a means to detect the applied force from a user.

[0071]The action arms by which the other end was combined with the axis of rotation in preparation for one end in the force receiving portion with which the training apparatus concerning this invention receives the applied force from a user, The motor made to generate the reaction force load of the direction which the rotation driving shaft is connected with the above-mentioned axis of rotation, and counters the above-mentioned applied force in the above-mentioned force receiving portion, The position detecting means which detects the rotary place of the above-mentioned axis of rotation, the speed detection means which detects the revolving speed of the above-mentioned axis of rotation, The load table which memorized the relation between the applied force instructions set up corresponding to the predetermined applied force-position change characteristic, and the rotary place of the axis of rotation, Speed command = so that a deviation with the speed detection value from the speed command generation circuit which outputs zero, and the zero speed command and the above-mentioned speed detection means from this speed command generation circuit may be inputted and this deviation may serve as zero, The torque command creation circuit which creates the torque command of the above-mentioned motor by control which has a proportional element and an integral element at least, And the applied force instructions equivalent to the rotary place detection value from the above-mentioned position detecting means are read in the above-mentioned load table, Since it had the limiting circuit which restricts the output of the above-mentioned torque command creation circuit so that the read applied force instructions concerned may serve as the maximum, it becomes the composition of open

control to applied force, and the stable reaction force load-control characteristic is obtained.

[0072]The proportional gain of the torque command creation circuit in the training apparatus concerning this invention, When a speed detection value changes in the direction which tends toward the position of an initial shock posture from the position of an ending posture and the polarity of a deviation input is reversed, Since the torque command which increases rapidly by negative polarity is generated and it was made to make the output of the above-mentioned torque command creation circuit decrease rapidly with the output of this proportional gain, Even if a user operates loosening the applied force suddenly etc. in the process in which it tends toward an ending posture from an initial shock posture, a risk of the reaction force load by a servo motor working to a user is prevented.

[Translation done.]

* NOTICES *

JPO and INPIT are not responsible for any damages caused by the use of this translation.

- 1.This document has been translated by computer. So the translation may not reflect the original precisely.
- 2.**** shows the word which can not be translated.
- 3.In the drawings, any words are not translated.

DESCRIPTION OF DRAWINGS

[Brief Description of the Drawings]

[Drawing 1]It is a figure showing in image the training state which uses the training apparatus which becomes an application concerned.

[Drawing 2]It is a figure showing the example of representation of the target applied force-position change characteristic by training.

[Drawing 3]It is a block diagram of the training apparatus in this embodiment of the invention 1 showing especially a working part.

[Drawing 4]It is a block diagram of the training apparatus in this embodiment of the invention 1 showing especially a control mechanism.

[Drawing 5]It is a flow chart for explaining operation of the training apparatus in this embodiment of the invention 1.

[Drawing 6]It is a block diagram of the training apparatus in this embodiment of the invention 2 showing especially a working part.

[Drawing 7]It is a block diagram of the training apparatus in this embodiment of the invention 2 showing especially a control mechanism.

[Drawing 8]It is a block diagram of the training apparatus in this embodiment of the invention 3 showing especially a control mechanism.

[Drawing 9]It is a flow chart for explaining operation of the training apparatus in this embodiment of the invention 3.

[Explanations of letters or numerals]

1 Action arms and 2 A force receiving portion and 3 The 1st axis of rotation and 4 Encoder, 5 The 2nd axis of rotation and 6 A torque meter, and 7 and 7A A servo motor and 8 Deceleration mechanism, 9 9A A load control device, 10 load tables, and 11 and 16 Subtractor, 12 and 17 A controller, and 13 and 14 An arithmetic

circuit, 15 speed-command generation circuit, 18 A proportional element and 19 An integral element and 20 An adding machine, 21 limiting circuits, PI [A speed command, V_f (Nm) rotation speed signal, and e / A velocity error, T_c torque command and T_m / Motor torque and R_m / Moderating ratio.] A rotary place and T_{hand} Applied force (operation torque) and T_{ref} An operation torque command, ΔT torque deviation, and V_{ref}

[Translation done.]

(19) 日本国特許庁 (J P)

(12) 公開特許公報 (A)

(11) 特許出願公開番号
特開2001-204850
(P2001-204850A)

(43) 公開日 平成13年7月31日 (2001.7.31)

(51) Int.Cl. ⁷	識別記号	F I	テマコード [*] (参考)
A 6 3 B 23/04		A 6 3 B 23/04	Z
	23/12	23/12	
// A 6 1 H 1/02		A 6 1 H 1/02	N

審査請求 未請求 請求項の数 8 O L (全 12 頁)

(21) 出願番号 特願2000-19577 (P2000-19577)

(22) 出願日 平成12年1月28日 (2000.1.28)

(71) 出願人 000000262
株式会社ダイヘン
大阪府大阪市淀川区田川2丁目1番11号

(72) 発明者 浦谷 隆文
大阪府大阪市淀川区田川2丁目1番11号
株式会社ダイヘン内

(72) 発明者 山口 耕作
大阪府大阪市淀川区田川2丁目1番11号
株式会社ダイヘン内

(74) 代理人 100093562
弁理士 児玉 俊英

最終頁に続く

(54) 【発明の名称】 トレーニング装置

(57) y v æ
y ɛ g p " > ' " ø p ɪ
œ v ~ ~ » † " ø - ~ " 導
o ~ ~ ɛ z ç 導
u »
y ɛ g p ' p ~ 變
fl ø p A [P A p A 變
> ¶ † " ø T [{ [^ 重
æ] ° u o ~ ~ g N 垂
ø p " ~ A fi p 垂
‡ œ % ɛ fi p " | ° u 導
[^ V fi S • ø 導

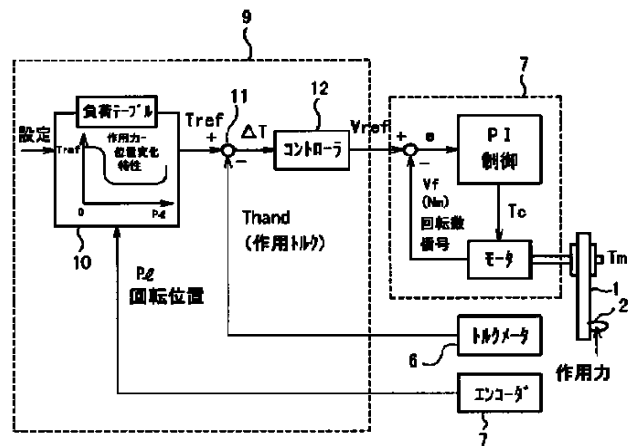

10: 負荷トルク
11: 減算器
12: コントローラ

y ˘ ɨ ʒ
 Y ɨ ɛ g p ˘ p ˘ ʒ
 • Ø ˘ fi 1 f A a L g ʒ
 p ɱ ˘ I fi p ɱ Ø ʒ
 p ˘ " b f Ø g ʒ
 a L g p ˘ p ˘ " ʒ
 L ˘ fi p ɱ ° u o ʒ
 ˘ @ B I ˘ † ɛ a L ʒ
 a L ˘ " > ʒ † ʒ
 L ˘ fi p ɱ ° u ˘ I fi ʒ
 ˘ » " ʒ L † ɛ % ʒ
 " Ø ˘ / a L % ˘ S ʒ
 ˘ ˘ ʒ
 Y ɨ Qz g p ˘ p ˘ ʒ
 [1 f ... [" P æ] ʒ
 a L g p ˘ p ˘ " ʒ
 ˘ a L P æ] † A ʒ
] • Ø β " a L % " Q æ] a ʒ
 [^ A a L P æ] † ʒ
 o L i A ɱ " ˘ a L g a N ʒ
 L i o " ˘ a L " p ˘ " ʒ
 o u " Ø a L ˘ p ˘ " ʒ
 p ˘ | ° u ˘ » ˘ « ˘ " ʒ
 fi S • Ø S L i ʒ
 [j O
 Y ɨ R g p ˘ p ˘ ʒ
 [1 f ... [" æ] † ʒ
] fi † " a L æ] † A ʒ
 β % " a L " ʒ
 ^ A a L T [{ [^ g ʒ
 { [^ æ] < x ' o • ʒ
 u " ° Ø ° u o L i ʒ
 ɱ " ° u ˘ a L ° u o L i ʒ
 ʒ L † ɛ % L p ʒ
 a L T [{ [^ fi S ʒ
 ˘ ˘ ʒ
 Y ɨ Sz S L i " A ʒ
 » ˘ « ˘ L † ɛ ʒ
 ° u ˘ W L fl % ʒ
 ˘ o l • Ø p ˘ ʒ
 ˘ L A p " o l ʒ
 / T [{ [^ < x ʒ
 æ H 1 f % - ˘ ˘ ʒ
 g [j B
 Y ɨ Z < x w < æ H " ʒ
 p ˘ w " " ˘ « A T ʒ
 L • Ø / % - ˘ ʒ

[j B
 Y ɨ Uz g p ˘ p ˘ ʒ
 • Ø ˘ fi 1 f A a L g ʒ
 p ɱ ˘ I fi p ɱ Ø ʒ
 p ˘ " b f Ø g ʒ
 a L ˘ fi p ɱ ° u ʒ
 fi ˘ @ B I ˘ † ɛ a ʒ
 " a L ˘ " > ʒ † ʒ
 a L ˘ fi p ɱ ° u ˘ I ʒ
 ˘ " » " ʒ L † ɛ % ʒ
 ˘ " Ø / a L % ˘ ʒ
 % - ˘ ˘ ʒ
 Y ɨ W g p ˘ p ˘ ʒ
 [1 f ... [" æ] † ʒ
] fi † " a L æ] † A ʒ
 β % " a L " ʒ
 æ] † æ] ° u o • Ø < x ʒ
 u ˘ » ˘ « ˘ L ʒ
 æ] ° u ˘ W L fl ʒ
 o " ° Ø < x w > ʒ
 L i o " < x w ˘ a L < ʒ
 ˘ " ° < x w " A - ˘ ʒ
 ˘ " ° < x w " v f ˘ ʒ
 g N w L i ' • Ø g ʒ
 L ° u o L i e [u ' ʒ
 w < æ H o " A Y ' ʒ
 ʒ ˘ • Ø ˘ S • Ø ʒ
 Y ɨ W g N w < æ H ʒ

7
 [j " O n p ^ [R L o • fi l " X Y % A N N Q [f • u u g y O A } p g i X e s a ~ I f { e b v o y p p X s < u e O v " fi < O } P O } } f [

8
 fl « " A - g e ~ " A " A æ N N . - Ø [x f Ø A [P " g o o i o E . fi e g " a ' A N Q Ø V A ^ -] R æ ¥ A W s N r S . Q @ ~ g v A p g X B E " % [R æ fi ° u } @ ~ g b e fi °

10
 20
 30
 40
 50

) Q i » Q j p ^ [是 i X e b v r R - m j A 尊
 j z f Ø - A a 斷 N . • ç s s | s 尊
 J Ł A ° ~ ~ 垂 f . A " " i P j fi - f 尊
 • Ø - ~ " Ø B • • 零 | s j ^ « 尊
 ‡ € % p " | ° u ~ » ` 垂 x w u < 尊
 ~ » • B Y O O R Y O O R Y E
 y O O R Q z g p ' 尊
 e [u P O ' p g 尊

$$V_{ref} = \text{Func}(T_{ref} - T_{hand})$$

$$= K \left\{ (T_{ref} - T_{hand}) + \frac{1}{T_i} \int (T_{ref} - T_{hand}) dt \right\} \quad \dots(1)$$

Y

$$T_m - \frac{T_{hand}}{R_m} = J \cdot \dot{N}_m + f \cdot N_m \quad \dots(2)$$

Y O O S R z - - - A q 章 Y O O S
 [^ + z « A " 章
 i Q j fi ~ \ ~ 章

$$T_{hand} = (T_m - J \cdot \dot{N}_m - f \cdot N_m) \cdot R_m \quad \dots(3)$$

Y O O S T z] \ ~ A Z 章 " - 章
 œ œ fl ø p g N 章 Y O O B z
 P j œ œ fl ø g N M 章 Y S
 M l m i | P j ~ ' 章

$$T_l(k) = Func(T_m(k-1), N_m(k-1))$$

$$= \left(T_m(k-1) - J \cdot \frac{\partial N_m(k-1)}{\partial \tau} - f \cdot N_m(k-1) \right) \cdot R_m \quad \dots(4)$$

13

14

j " « -) • Ø 雜
 ° A - < x . • B] ' ~] A 雜
 s Ø % " , • Ø B] ' ~] A 雜
 † E B T T z A fi p 雜
 y O O [j O s • Ø 雜
 g [t [[g • Ø 雜
 f • A [P O ~ " L X ^ [S i 10 雜
 p A [P O ~ " L X ^ [S i 10 雜
 n A " " fi] M ° u o " 雜
 [^ æ] I fi ° u i o e b 雜
 ' O j ~ » f • Ø i X 雜
 ' " Ø B T U z X e b v s P 雜
 y O O T U z X e b v s P 雜
 > ¶ æ H P T ' < x w V ^ 20 雜
 ~ S W † E Ø T [{ [^ - 雜
 R " A - O ^ f Ø M u x . 雜
 [^ ' s R j A - < x . 雜
 e b v s R j A - < x . 雜
 g y O O T V z ~ - ° - A - 雜
 ~ b ^ æ H Q P e [u - P O l 雜
 w s o h S ' ~ ç " ç ~ " « u 30 雜
 - ^ s " " « " A < x . • ~ 雜
 " " » p g A [p g ~ ^ s 雜
 [^ ~ p p A [p g ~ ^ s 雜
 ¶ O O T W z † E % H Q P N s 雜
 \ « " ~ b ^ æ • Ø % H Q P N s 雜
 x . • E , A » E Ø % H Q P N s 雜
 † E , A » E Ø % H Q P N s 雜
 [^ ~ p p A [p g ~ ^ s 雜
 s « A g p A ' ' Ø ~ " A - 雜
 fi « A g p A ' ' Ø ~ " A - 雜
 Ø \ | ° u L A » « (Z [雜
 y O O l i z ~ % " A p A [雜
 ~ " > A ~ » «

Ø B f ç A p g N 雜
 n L † , A ç . I [v 雜
 ~ A Ø E (r ~ P A Q 雜
 • Ø E U O z " n A } S W A m 雜
 y O O U O z " n A } S W A m 雜
 [^ ~ ç - " A G R [- " 雜
 < ~ ç - " A G R [- " 雜
 " A " U P † E % æ] † " ç • ~ 雜
 y O O U P † E % æ] † " ç • ~ 雜
 P " < @ ¥ W , < @ ¥ W < ~ 雜
 , < @ ¥ W , < @ ¥ W < ~ 雜
 [^ ~ a q % ~ fl l † 雜
 y O O U Q z X ' A Ø q 雜
 O E ß Ø ß ~ s / " A fl l 雜
 fi . s / " A fl l 雜
 g [j Ø B f ç A E ß - S 雜
 t • Ø ~ A f Ø - L t Y 雜
 " • Ø ~ A f Ø - L t Y 雜
 n ~ • E 雜
 y O O U R z % A Ø q 雜
 [" g p † E % p " A [fl 雜
 Q fi p n ' I % " A - > ~ " 雜
 ç . A - " Ø " A - > ~ " 雜
 f v ~ fl f " @ ¥ ~ æ] † 雜
 K v ~ fl f " @ ¥ ~ æ] † 雜
 ç A A K L ... ^ fi ~ A { † 雜
 L A a L ... ^ fi ~ A { † 雜
 • E . E % ç B] † ~ A { † 雜
 † E % ç B] † ~ A { † 雜
 y O O U S z X g A " a - 雜
 Ø Ø fi S z X g A " a - 雜
 L > u p K " | u [雜
 " B W z 雜

y	>		ł	°	z	"	a		/	專
Ø	'	fi	"	A	g	p	'	L	g	專
π	'	I	fi	1	f	A	a	L	g	專
	'	"	p	b	f	π	Ø	g	[專
	p	π	°	u	p	"	o	•	Ø	專
I			‡	⊕	a	L	p	°	~	專
L	"	°	u	'	¶	‡	"	Ø	π	專
π		°	Ł	‡	⊕	Ł	Ł	•	Ø	專
¥	L	°	"			§	Ø	•	p	專
a	L	°	"				fi	Ø	p	專
p		°	u	~	»	'	«		•	專
"	O	"	U	U	z	°	A	-	>	專
y	O	O	U	U	'			p	"	專
"	A	g	P	p	æ]	†	o	•	專
["		p	p	"	A	†	⊕	°	專
'	æ]	†	Q	æ]	†	⊕	°	專
a	L	"	Q	æ]	a	L	"	°	專
L	°	P	a	L	g]	†	æ]	專
~		"		"	a	L	fi	p	π	專

17

< - } . Ø g N w 譽 y } Y - > (' 譽

~ L a L g N w 譽 O u A \ S @ 譽

／ % - A fi p n ' 譽 y } W - > (' 譽

P " > p ~ } 譽 O u A \ S @ 譽

{ [^ Ø % " " 譽 y } X - > { ' 譽

~ † 譽 O u fi 譽 . Ø % 譽

y } ° " 譽 y } z 譽

y } E { L " Ø g [j 譽 P p A [譽

[j o C [譽 G R 譽 Q æ 譽 g N 譽

y } Ø g [j o - W 1 譽 V C V T [{ 譽 , < @ ¥ 譽

` « a ¥ E 譽 S 譽 e [u 譽 , Z 譽

y } E - > { ' 譽 譽 A P 譽 R g [譽 譽

O u A \ @ ¥ 譽 譽 H A P < x w > 譽 E v 譽

y } S - > { ' 譽 譽 ~ " v f 譽

O u A \ S @ 譽 譽 æ] ° u A s p ~ i p g 譽

y } Z - > (' 譽 譽 x p g N 譽 g N . • A < 譽

O u fi . Ø % 譽 譽 x w A u 譽 æ] M 譽

y } W - > { ' 譽 譽 g N w A [^ g 譽 , < B 譽

O u A \ @ ¥ 譽 譽

18

y } Y - > (' 譽

O u A \ S @ 譽

y } W - > (' 譽

O u A \ S @ 譽

y } X - > { ' 譽

O u fi . Ø % 譽

y } z 譽

P p A [譽

G R 譽 Q æ 譽 g N 譽

V C V T [{ 譽 , < @ ¥ 譽

S 譽 e [u 譽 , Z 譽

A P 譽 R g [譽 譽

H A P < x w > 譽 E v 譽

~ " v f 譽

æ] ° u A s p ~ i p g 譽

x p g N 譽 g N . • A < 譽

x w A u 譽 æ] M 譽

g N w A [^ g 譽 , < B 譽

y } E

y } Ø

(a)

(b)

(c)

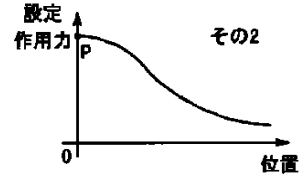
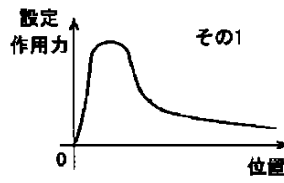
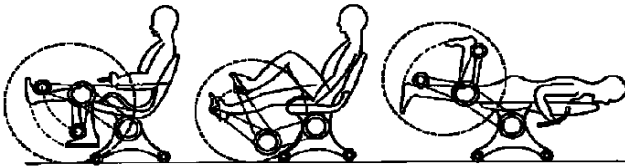

y } S

y } E

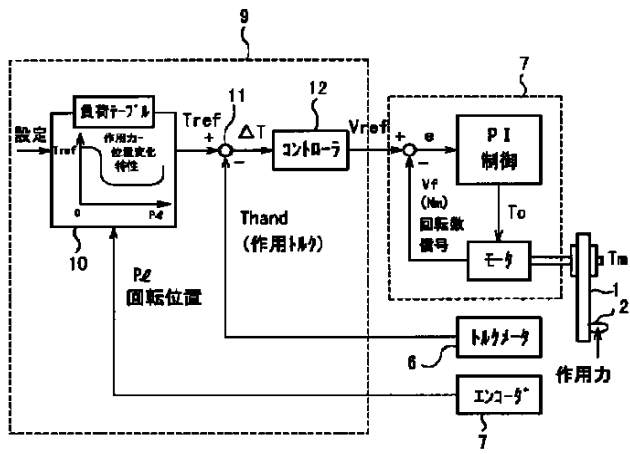

- 10: 負荷トルク
- 11: 減算器
- 12: コントローラ

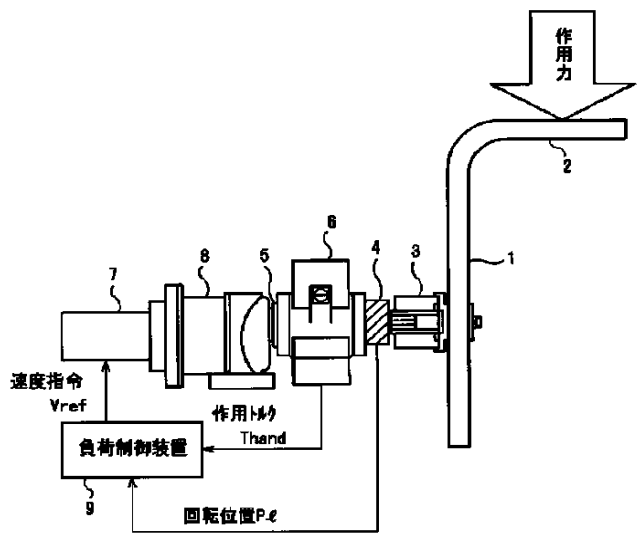

- 1: 作用7-A
- 2: 受力部
- 3: 第1の回転軸
- 4: エンコーダ
- 5: 第2の回転軸
- 6: トルクメータ
- 7: サブモータ
- 8: 減速機構
- 9: 負荷制御装置

y } z

y } 0

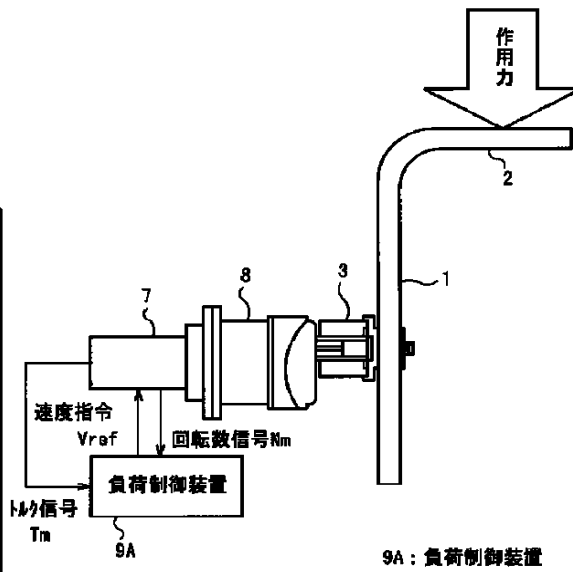
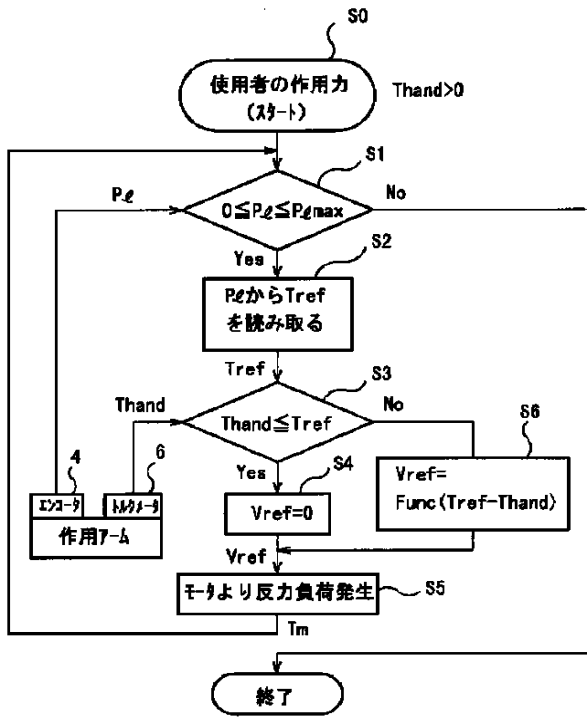

9A: 負荷制御装置

y } x

y } z

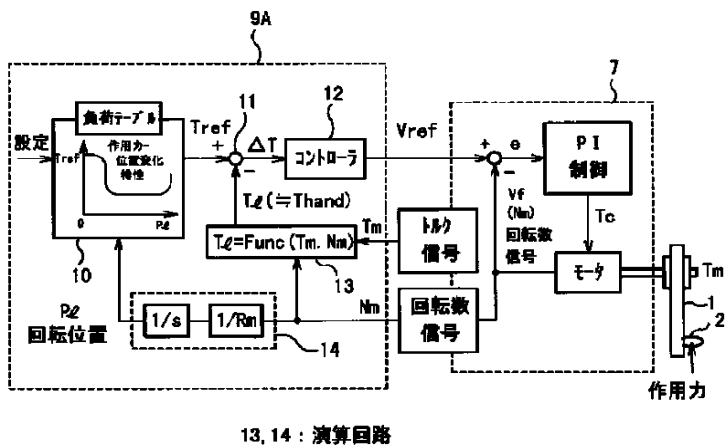

13, 14: 演算回路

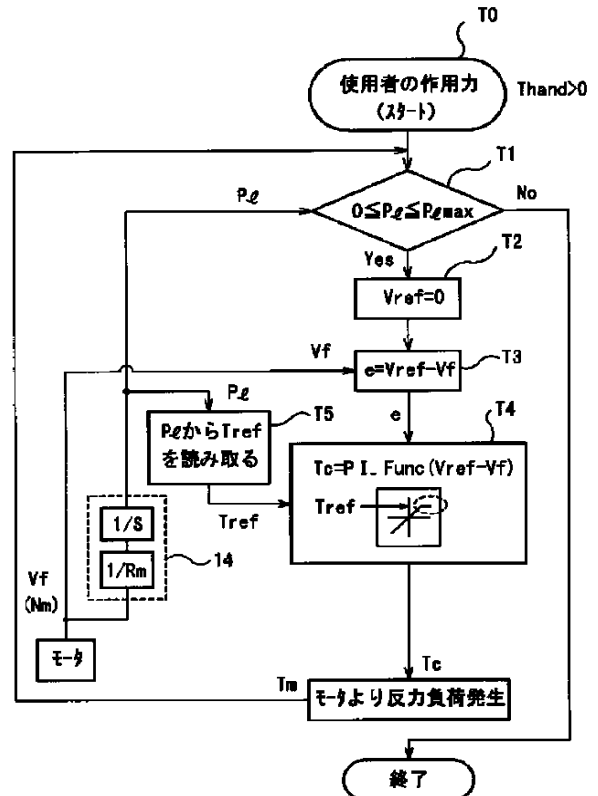

y) 図

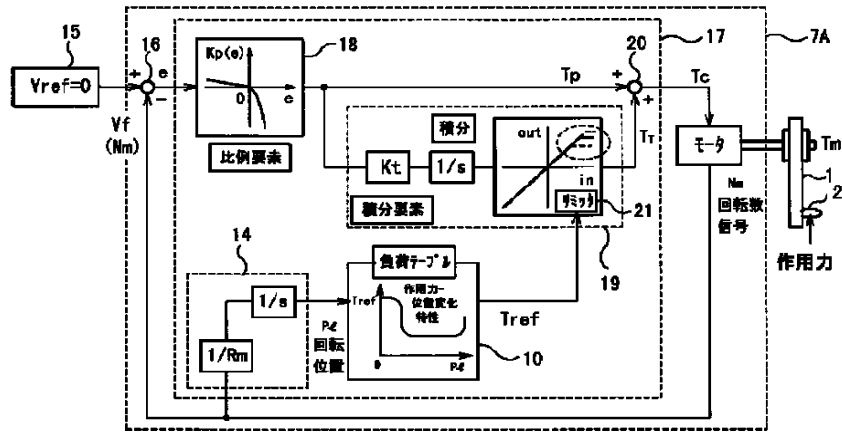

- | | |
|---------------|------------|
| 7A : モータ | 18 : 比例要素 |
| 15 : 速度指令発生回路 | 19 : 積分要素 |
| 16 : 減算器 | 20 : 加算器 |
| 17 : コントローラ | 21 : ミキサ回路 |